

Renewable Hydrogen: Integration, Validation, and Demonstration

Conference Paper
NREL/CP-581-43114
July 2008

K.W. Harrison and G.D. Martin

*Prepared for the 2008 NHA Annual Hydrogen Conference
Sacramento, California
March 30 – April 3, 2008*

NREL is operated by Midwest Research Institute • Battelle Contract No. DE-AC36-99-GO10337



NOTICE

The submitted manuscript has been offered by an employee of the Midwest Research Institute (MRI), a contractor of the US Government under Contract No. DE-AC36-99GO10337. Accordingly, the US Government and MRI retain a nonexclusive royalty-free license to publish or reproduce the published form of this contribution, or allow others to do so, for US Government purposes.

This report was prepared as an account of work sponsored by an agency of the United States government. Neither the United States government nor any agency thereof, nor any of their employees, makes any warranty, express or implied, or assumes any legal liability or responsibility for the accuracy, completeness, or usefulness of any information, apparatus, product, or process disclosed, or represents that its use would not infringe privately owned rights. Reference herein to any specific commercial product, process, or service by trade name, trademark, manufacturer, or otherwise does not necessarily constitute or imply its endorsement, recommendation, or favoring by the United States government or any agency thereof. The views and opinions of authors expressed herein do not necessarily state or reflect those of the United States government or any agency thereof.

Available electronically at <http://www.osti.gov/bridge>

Available for a processing fee to U.S. Department of Energy and its contractors, in paper, from:

U.S. Department of Energy
Office of Scientific and Technical Information
P.O. Box 62
Oak Ridge, TN 37831-0062
phone: 865.576.8401
fax: 865.576.5728
email: <mailto:reports@adonis.osti.gov>

Available for sale to the public, in paper, from:

U.S. Department of Commerce
National Technical Information Service
5285 Port Royal Road
Springfield, VA 22161
phone: 800.553.6847
fax: 703.605.6900
email: orders@ntis.fedworld.gov
online ordering: <http://www.ntis.gov/ordering.htm>



RENEWABLE HYDROGEN: INTEGRATION, VALIDATION, AND DEMONSTRATION

K. W. Harrison ¹
G. D. Martin ¹

1. Introduction

Renewable energy (RE) sources such as photovoltaic (PV), wind, biomass, hydro, and geothermal can provide clean and sustainable energy for our nation. Several of these options are already cost-competitive and are contributing nearly 10% of the U.S. electricity supply. Limiting greater penetration of some of these renewable energy sources, however, is their inherent variability and seasonal energy production.

One solution to this problem is to produce hydrogen through the electrolysis of water and use the hydrogen in a fuel cell or internal combustion engine to produce electricity during times of peak demand or as a transportation fuel. Currently, this approach is hindered, in part, by the difficulty of producing hydrogen from these RE sources in a cost-competitive manner. In addition to the ongoing efforts to reduce the cost of RE technologies and to lower the capital requirements for electrolyzers, these renewable electrolysis systems must be optimized and tailored to realize the most cost-competitive option for electricity and hydrogen production.

Producing hydrogen with domestic renewable resources reduces the impact of greenhouse gases. Wind energy is currently the lowest cost renewable energy source, so it's the leading near-term candidate. Wind also is a variable energy source. In the mid- to long-term it may be beneficial to produce hydrogen when electricity created by the wind is not needed, and then add generation from hydrogen when electricity demand is high. Energy storage systems have the potential for addressing electric system integration issues inherent with variable wind energy resources, thereby enabling higher amounts of wind power on the electric system. This all aligns with the nation's interest in developing and demonstrating advanced hydrogen technologies to reduce our dependence on foreign energy resources, improve our air quality, and ultimately support our long-term economic viability.

2. Background

Today, nearly every commercially available electrolyzer is designed for grid-connected operation; therefore, they incorporate power electronics (PE) to convert alternating current (AC) from the grid to direct current (DC) required by the electrolyzer cell stack. These power converters can represent 25% to 30% of the total cost of the electrolyzer. Power converters are also required for the RE

¹ National Renewable Energy Laboratory, 1617 Cole Blvd., Golden, CO 80401

source. For example, variable-speed wind turbines use PE to convert the variable frequency, variable voltage that is produced at the generator to DC; when connected to the grid, this voltage must be converted back to AC at grid frequency (60 Hz).

Hydrogen production, via electrolysis, is highly dependent on the delivered cost of electricity. This research includes analysis of hydrogen storage options and electrolyzer component-level studies to help reveal areas to reduce the overall cost of hydrogen production. These studies aim to develop and optimize new controls, subsystems, and power electronics configurations for renewable electrolysis systems. Experimental testing provides feedback to the analysis to verify system efficiency improvements. Ultimately, the results of this research will reduce capital costs of renewable electrolysis systems through reduced energy designs, lower cost materials, and improved performance with RE sources.

3. Technical Targets

By addressing the technical barriers of capital costs, system efficiency, and integration with renewable energy sources, the National Renewable Energy Laboratory (NREL) is working to achieve the Department of Energy's (DOE's) cost targets for distributed and central electrolytic hydrogen production.

Distributed Electrolysis

- By 2012, reduce the cost of distributed production of hydrogen from distributed electrolysis to \$3.70/gge of hydrogen (delivered) at the pump.
- By 2017, reduce the cost of distributed production of hydrogen from distributed electrolysis to less than \$3.00/gge of hydrogen (delivered) at the pump.

Central Electrolysis

- By 2012, reduce the cost of central production of hydrogen from wind electrolysis to \$3.10/gge of hydrogen at the plant gate (\$4.80/gge delivered).
- By 2017, reduce the cost of central production of hydrogen from wind electrolysis to less than \$2.00/gge of hydrogen at the plant gate (less than \$3.00/gge delivered).

Component-Level Analysis

A capital cost component analysis is being conducted as part of the renewable electrolysis work at NREL. The component cost analysis aims to break down the cost of system-level components within each subsystem to help determine where further research could help reduce the system capital costs. The goal is to have a manageable, yet detailed enough, analysis to identify key areas where cost might be reduced or efficiency increased in the integrated renewable system framework.

In the first stage, inquiries to various manufacturers of commercial and research-level electrolyzer systems will be used to create a breakdown of the various

components as a percentage of total cost. Rather than looking at exact unit costs, the data will be viewed as parts of a whole to identify the largest opportunities for improvement. A normalization of inputs and outputs will occur to eventually fit this into the integrated system cost analysis. Identification of components with greatest cost reduction potential or that serve redundant purposes within an integrated renewable system framework can be used to make hydrogen production more economical and efficient.

4. Integration

Essentially, the entire renewable electrolysis system is limited by the constraints imposed by the PE interfaces between components. There are a number of weaknesses with this configuration, namely a redundancy of PE leading to increased cost, potential for failure, and a lack of ability to match RE power output to electrolyzer stack power requirements. One goal of testing an electrolyzer stack closely coupled with a wind-turbine generator or PV array is to determine the effect of fluctuating power output on electrolyzer stack and system operation. The presence of a battery bank serves to fix the common bus voltage as well as smooth the power input to the electrolyzer stack, thus somewhat defeating the purpose and adding to system cost.

10 kW PV

NREL has designed, constructed, and begun testing a DC/DC power converter to be used with the 10 kW PV system at NREL's Distributed Energy Resources Test Facility (DERTF). The focus of this power converter design is to reduce cost, increase flexibility of energy input, and to bring the system closer to commercial viability than previous designs using unique controllers and software. An off-the-shelf programmable logic controller (PLC) is interfaced with an off-the-shelf insulated-gate bipolar transistor (IGBT)-based PE module to step-down the DC voltage from the PV array to that required by the electrolyzer stack. The system was designed to be low-cost, easily programmable, and tuned using commercially available components. The new design will take advantage of many of the recent advances in semiconductor power electronics including higher power density and reduced thermal resistance. Closed-loop current-control to the electrolyzer stacks and maximum power point tracking (MPPT) of the PV array will provide improved performance and efficiency.

10 kW Wind

Using knowledge of both the performance characteristics of a 10-kW permanent-magnet wind turbine and electrolyzer stack, we developed a solution that replaced the two separate PE interfaces with a single one that takes varying magnitude and frequency AC directly from the generator output and provides acceptable DC power to the electrolyzer stack, thereby reducing the cost and increasing the robustness of the wind turbine-electrolyzer stack link.

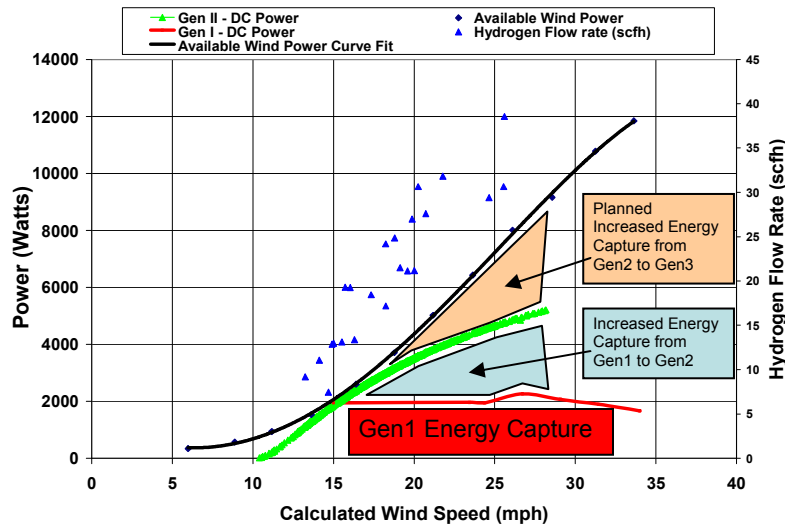

Figure 1 Composite graph of improved power capture of second generation power electronics design

Figure 1 shows the increase in energy capture (blue shade) from the first generation PE design (red line) to the second generation (green line). In 2008 we plan to complete the testing with additional modifications to further improve the performance and capture some (if not all) of the red shaded area. The single point of control allows matching of the wind turbine and electrolyzer stack electrical characteristics, thereby increasing the energy capture of the wind turbine.

100 kW Wind

Some energy from a 100-kW variable-speed wind turbine will be “picked off” from the existing power controller which already produces a DC bus between 750 and 800 V. That voltage is too high for the electrolyzer stacks and PE is being designed to make the DC-DC conversion. The 30-kW alkaline electrolyzer stack requires a maximum of approximately 150 Vdc. Thus, a DC-DC converter topology with a sufficient power rating is required to perform the conversion. To address this, we designed an isolated DC-DC converter using a full bridge, single phase inverter coupled with a rectifier and energy storing inductor. A 10-kHz, 30-kVA transformer connects the inverter to the rectifier, providing electrically isolated energy transfer. This circuit (Figure 2) was simulated using Matlab Simulink software, and a simple feedback control system was integrated in the simulation.

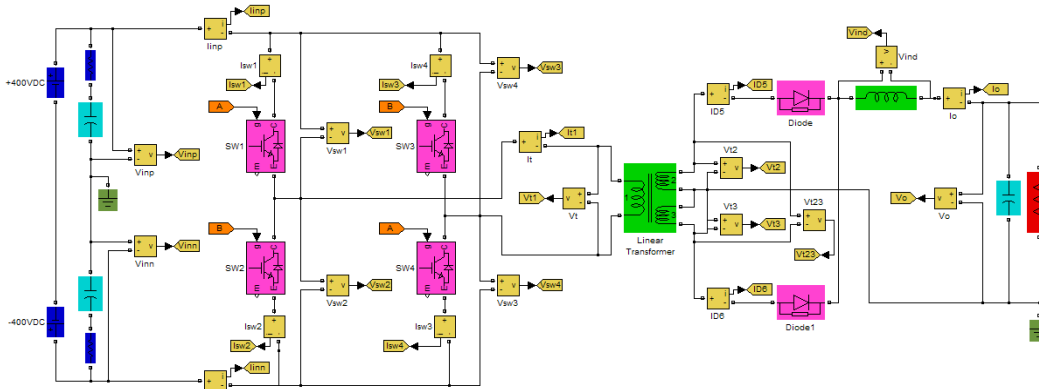

Figure 2 Simulation schematic illustrating the electrical topology of the full-bridge DC-DC converter.

5. Validation

NREL is currently completing testing of a polymer electrolyte membrane (PEM)-based electrolyzer module. The system, model EP1 (Figure 3), is installed at NREL’s National Wind Technology Center (NWTC) in the Hydrogen Test Facility (HTF), which is adjacent to the DERTF. The electrolyzer is designed and built by Giner Electrochemical Systems, with support from the DOE, to demonstrate differential high-pressure (~1000 psig) PEM electrolysis with improved stack efficiency and cost. The electrolyzer is being tested to provide independent verification of stack efficiency towards the DOE’s Joule Milestone EE GG 1.1.01.1, which states: “Complete lab-scale electrolyzer, test to determine whether it achieves 64% energy efficiency, and evaluate systems capability to meet \$5.50/gge hydrogen cost target, untaxed at the station, and with large equipment production volumes [e.g., 500 units/year].”



Figure 3 Giner's PEM-based Electrolyzer Module installed at NREL's Hydrogen Test Facility.

The electrolyzer stack contains 28 cells connected in series. The average stack voltage was found to be 52.8 V resulting in an average cell voltage of 1.89 V. The stack efficiency was determined to be 67% when the pressure and temperature compensated Nernst potential equal to 1.27 V/cell (50.8°C, 65 atm) was divided by the actual cell voltage 1.89 V/cell.

$$\text{Stack Efficiency} = \frac{\text{Ideal Stack Potential}}{\text{Actual Stack Potential}} = \frac{1.27}{1.89}(100) = 67\%$$

1.1. Test Procedures

NREL has developed a draft document that provides recommended tests, procedures, and specifications for qualification tests intended to evaluate electrolytic hydrogen-production equipment under varying power input. The intent of this recommended practice is to extend the basic testing arrangements provided by the International Organization for Standardization (ISO), “Hydrogen generators using water electrolysis process — Part 1: Industrial and commercial applications.” The tests provided are aimed at evaluating hydrogen generator operation and performance at lower power levels, like those that exist when powered with RE sources.

Nearly all of the commercial electrolytic hydrogen generators available today are powered entirely by regulated AC sources from the utility grid. The DC required by the stack is derived by rectifying the grid AC with on-board PE. The majority (~85%) of energy required by a hydrogen generator system is consumed as DC by the hydrogen-producing stack. A hydrogen generator powered in part or wholly by a RE source will be subjected to the intrinsic time variable nature of the source. Power variations from RE sources present challenges in quantifying performance not typically experienced with a grid-connected system.

For example, to enable the qualification of the hydrogen generator at varying stack power levels, an external or software-controlled adjustment of stack DC power is required (Figure 4). Typical ways to accomplish this adjustment might be to use internal software with operator access to control the power supply set point or to use a trim potentiometer to limit the DC power supply to the stack. Stack voltage and current transducers will verify the various power level set points.

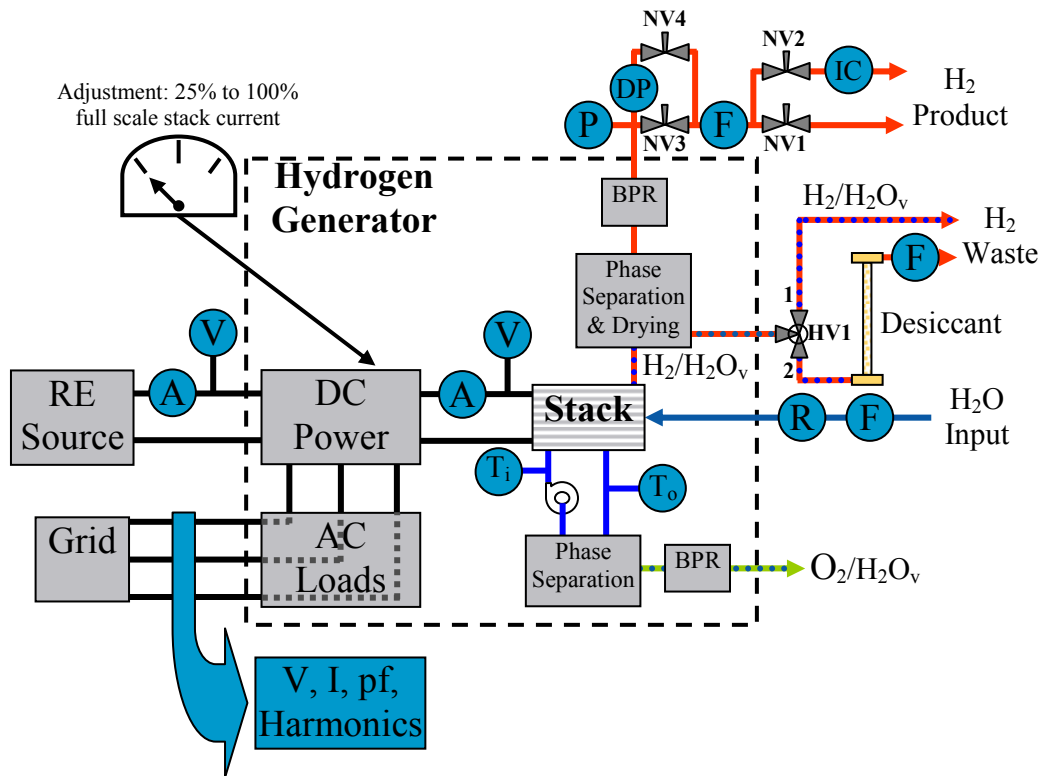

Figure 4 System monitoring transducer placements

6. Demonstration

A cooperative research and development agreement (CRADA) was created between Xcel Energy and NREL to investigate ways to improve the system efficiency of producing, delivering, and using hydrogen from renewable resources. The wind-to-hydrogen (Wind2H₂) demonstration project aims to quantify system-level efficiency improvements and cost reductions by designing, building, and integrating dedicated RE-to-electrolyzer stack PE. The goal of the project is to enable closer coupling of RE-generated electricity and the electrolyzer stack to produce hydrogen, which is then compressed and stored for future use to produce electricity via a hydrogen-fueled internal combustion engine for grid-connected peaking power applications, or, in the future, as a vehicle fuel.

The project will use two wind turbine technologies: a Northern Power Systems 100-kW (NW100a) wind turbine and a Bergey 10-kW wind turbine. Both wind turbines are variable speed in that the blades' speed varies with wind speed. Variable speed wind turbines produce AC that varies in magnitude and frequency (known as "wild" AC) as the wind speed changes. The energy from the 10 kW wind turbine will be converted from its wild AC form to DC, then used by one of the 6-kW PEM electrolyzer stacks to produce hydrogen and oxygen from water. The energy from the 100-kW wind turbine will be captured from its existing controller, which already powers a variable DC bus of roughly ± 400 V. That

voltage is too high for the electrolyzer stacks, and new PE will be designed to make the necessary conversion.

Information on the Wind2H2 is located on the NREL Web site at http://www.nrel.gov/hydrogen/proj_wind_hydrogen.html.

One goal of this work is to characterize system performance and develop PE converters and control algorithms to optimize the production of hydrogen from wind power. Baseline testing of the Xcel/NREL Wind2H2 project is providing data about system performance under steady power provided from the utility (Figure 5).

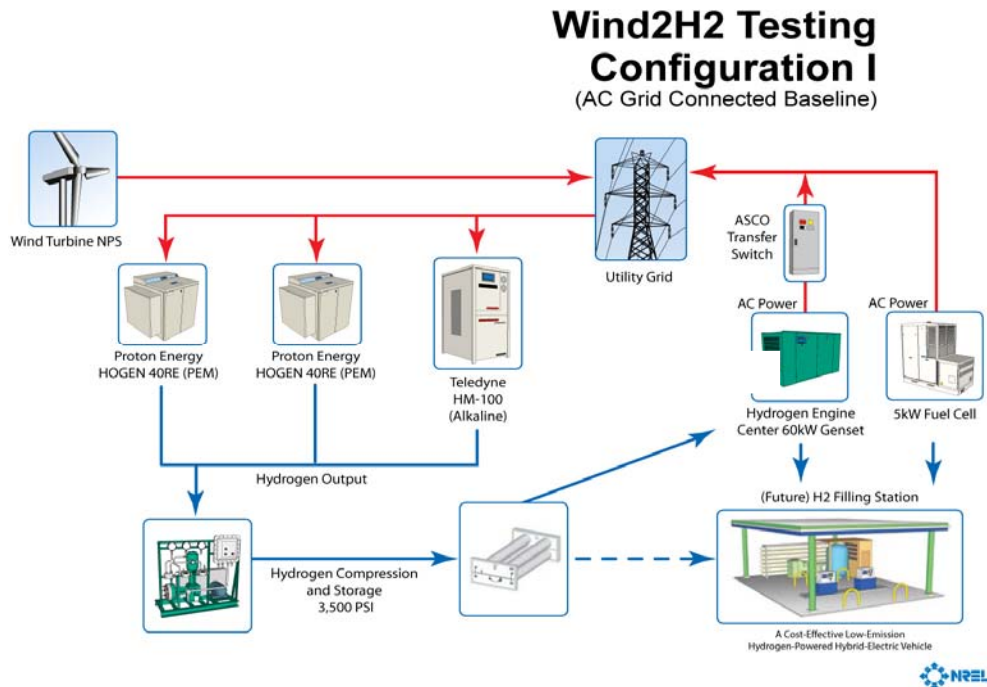

Figure 5. System configuration for utility connected baseline testing

Power for the stacks of two HOGEN 40RE PEM electrolyzers (Proton Energy Systems) and one alkaline electrolyzer (Teledyne Energy Systems) will be the focus of much of the research. The project will examine issues surrounding the integration of both technologies as well as how to operate electrolyzers of different product pressures in parallel. The demonstration project will reveal integration and operational issues as well as identify opportunities for improvement and other potential benefits for consumers.

Wind2H2 Testing

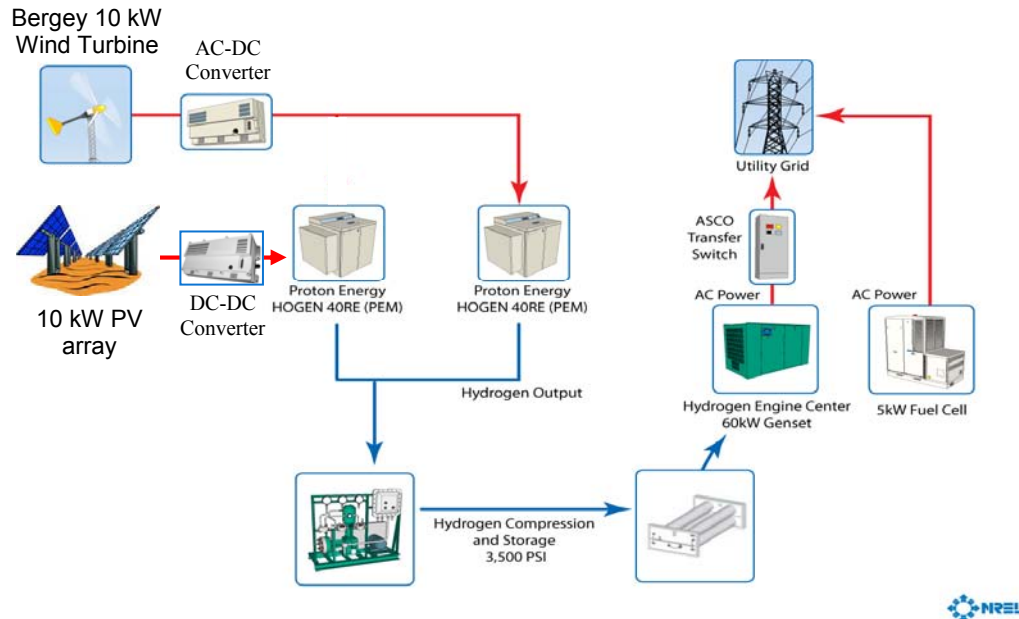

Figure 6 System configuration for 10-kW stand-alone wind turbine to 6-kW electrolyzer stack testing.

In 2007, the Wind2H2 construction project began normal operations focused on baseline (i.e., utility- or grid-tied operation). A second generation AC to DC power converter was designed, modeled, built, and tested to provide power from the 10-kW wind turbine to one or both of the PEM electrolyzer stacks (Figure 6).

Other key research goals include:

- Creating synergies from the co-production of electricity and hydrogen
- Addressing the variable nature of wind power by storing hydrogen for later use, creating a ready source of electricity for when the wind doesn't blow or the demand for electricity is high
- Producing hydrogen for use in vehicles
- Comparing multiple electrolyzer technologies to gauge their efficiencies and abilities to accommodate the variable input power of RE sources
- Achieving efficiency gains through unique, integrated AC-to-DC and DC-to-DC power converters between the wind turbines, PV array, and the electrolyzer stacks.

Future work will include sensor calibrations and hardware to allow direct communications with the various devices for automated unattended operation. The ~800 Vdc from the NW100 wind turbine to 150 Vdc power converter is currently being designed to power the 30-kW alkaline electrolyzer stack.

7. Summary

Two PE systems were designed and tested using a small 10-kW wind turbine and 10-kW PV array connected to a 6-kW electrolyzer stack. A larger 30-kW PE converter is being designed to perform a DC-DC conversion, using power from a 100-kW wind turbine to power the alkaline electrolyzer stack.

We began testing the electrolyzer from Giner Electrochemical Systems by verify the stack voltage efficiency. The stack is operated at a nominal 250 A_{dc} resulting in an average stack voltage of 52.8 V_{dc}. The stack efficiency was determined to be 67% when the pressure and temperature compensated Nernst potential equal to 1.27 V (50.8°C, 65 atm) was divided by the actual cell voltage 1.89 V. System efficiency testing is currently being completed.

The Xcel/NREL Wind2H2 project is running under grid-connected power to establish baseline performance levels. Both the 10-kW wind turbine and 10-kW PV power electronics were tested on the system as well. Improvements in energy capture are being pursued for both of the power converters, while the design of the larger 30-kW device is being completed.

REPORT DOCUMENTATION PAGE

Form Approved
OMB No. 0704-0188

The public reporting burden for this collection of information is estimated to average 1 hour per response, including the time for reviewing instructions, searching existing data sources, gathering and maintaining the data needed, and completing and reviewing the collection of information. Send comments regarding this burden estimate or any other aspect of this collection of information, including suggestions for reducing the burden, to Department of Defense, Executive Services and Communications Directorate (0704-0188). Respondents should be aware that notwithstanding any other provision of law, no person shall be subject to any penalty for failing to comply with a collection of information if it does not display a currently valid OMB control number.

PLEASE DO NOT RETURN YOUR FORM TO THE ABOVE ORGANIZATION.

1. REPORT DATE (DD-MM-YYYY) July 2008		2. REPORT TYPE Conference Report		3. DATES COVERED (From - To)	
4. TITLE AND SUBTITLE Renewable Hydrogen: Integration, Validation, and Demonstration				5a. CONTRACT NUMBER DE-AC36-99-GO10337	
				5b. GRANT NUMBER	
				5c. PROGRAM ELEMENT NUMBER	
6. AUTHOR(S) K.W. Harrison and G.D. Martin				5d. PROJECT NUMBER NREL/CP-581-43114	
				5e. TASK NUMBER H2713730	
				5f. WORK UNIT NUMBER	
7. PERFORMING ORGANIZATION NAME(S) AND ADDRESS(ES) National Renewable Energy Laboratory 1617 Cole Blvd. Golden, CO 80401-3393				8. PERFORMING ORGANIZATION REPORT NUMBER NREL/CP-581-43114	
9. SPONSORING/MONITORING AGENCY NAME(S) AND ADDRESS(ES)				10. SPONSOR/MONITOR'S ACRONYM(S) NREL	
				11. SPONSORING/MONITORING AGENCY REPORT NUMBER	
12. DISTRIBUTION AVAILABILITY STATEMENT National Technical Information Service U.S. Department of Commerce 5285 Port Royal Road Springfield, VA 22161					
13. SUPPLEMENTARY NOTES					
14. ABSTRACT (Maximum 200 Words) This paper is about producing hydrogen through the electrolysis of water and using the hydrogen in a fuel cell or internal combustion engine generator to produce electricity during times of peak demand, or as a transportation fuel.					
15. SUBJECT TERMS hydrogen; renewable hydrogen; electrolyzer; grid; fuel cell; integration; electrolysis; polymer electrolyte membrane; PEM					
16. SECURITY CLASSIFICATION OF:			17. LIMITATION OF ABSTRACT UL	18. NUMBER OF PAGES	19a. NAME OF RESPONSIBLE PERSON
a. REPORT Unclassified	b. ABSTRACT Unclassified	c. THIS PAGE Unclassified			19b. TELEPHONE NUMBER (Include area code)

Standard Form 298 (Rev. 8/98)
Prescribed by ANSI Std. Z39.18